



## Zener Diodes: BZT52CxxxAU-UPA Series

Rev.1.1

### FEATURE

- ◇ Silicon power zener diodes.
- ◇ Low zener impedance.
- ◇ 500mW rating on FR-4 or FR-5 board.
- ◇ Voltage range includes breakdown voltages from 3.0V to 4.3V with approximately  $\pm 5\%$  for BZT52CxxxAU-UPA series.
- ◇ Low profile surface-mount package.
- ◇ AEC-Q101 qualified.
- ◇ For use in stabilizing and clamping circuits with high power rating.

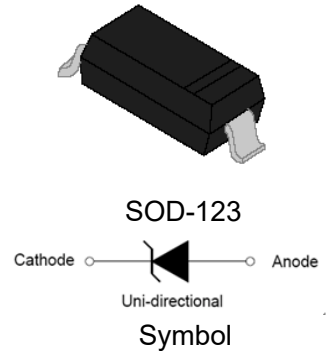

### ABSOLUTE MAXIMUM RATINGS AND THERMAL CHARACTERISTICS

Parameter	Symbol	Max Value	Unit
Total power dissipation @ $T_L=75^\circ\text{C}$	$P_D$	500	mW
Thermal resistance junction to ambient (Note1)	$R_{\theta JA}$	330	$^\circ\text{C}/\text{W}$
Junction temperature range	$T_J$	-55 to +150	$^\circ\text{C}$
Storage temperature range	$T_{STG}$	-55 to +150	$^\circ\text{C}$

Note1: Device mounted on FR-4 PCB with minimum recommended pad layout

### ELECTRICAL CHARACTERISTICS ( $T_A=25^\circ\text{C}$ )

Symbol	Parameter
$V_Z$	Reverse zener voltage at $I_{zt}$
$I_{zt}$	Reverse current
$I_R$	Reverse leakage current at $V_R$
$V_R$	Reverse voltage
$I_F$	Forward current
$V_F$	Forward voltage at $I_F$

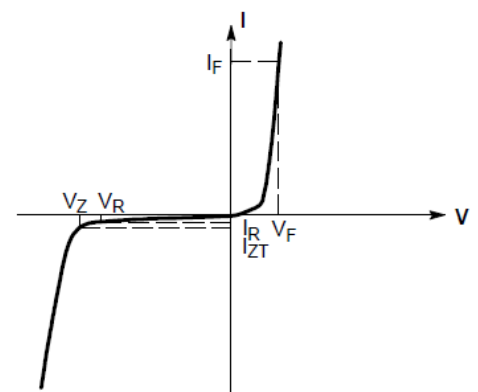

Zener voltage regulator

**MARKING**



W2: Device Marking Code

**ELECTRICAL CHARACTERISTICS** (T<sub>A</sub>=25°C unless otherwise noted)

Maximum V<sub>F</sub>=0.9V at I<sub>F</sub>=10mA

Type number	Zener voltage range at I <sub>zt</sub>				Maximum zener impedance			Maximum reverse leakage current		Typical temperature coefficient @I <sub>zTC</sub>		Test current I <sub>zTC</sub>	Marking
	Nom (V)	Min (V)	Max (V)	I <sub>zt</sub> (mA)	Z <sub>zt</sub> (Ω)	Z <sub>zk</sub> (Ω)	I <sub>zk</sub> (mA)	I <sub>R</sub> (μA)	V <sub>R</sub> (V)	Min (mV/°C)	Max (mV/°C)	mA	
BZT52C3V0AU-UPA	3.0	2.8	3.2	5.0	95	600	1.0	1	1.0	-3.5	0	5	W2
BZT52C3V3AU-UPA	3.3	3.1	3.5	5.0	95	600	1.0	1	1.0	-3.5	0	5	W3
BZT52C3V6AU-UPA	3.6	3.4	3.8	5.0	90	600	1.0	1	1.0	-3.5	0	5	W4
BZT52C3V9AU-UPA	3.9	3.7	4.1	5.0	90	600	1.0	1	1.0	-3.5	0	5	W5
BZT52C4V3AU-UPA	4.3	4.0	4.6	5.0	90	600	1.0	1	1.0	-3.5	0	5	W6

**ORDERING INFORMATION**

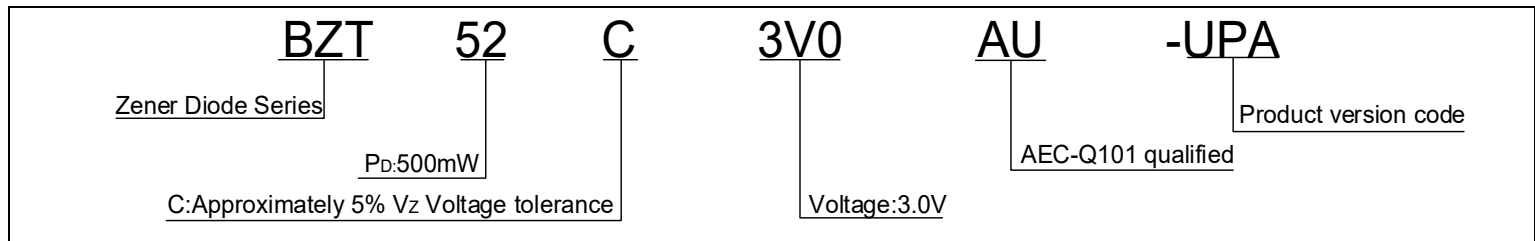

PACKAGE MECHANICAL DATA

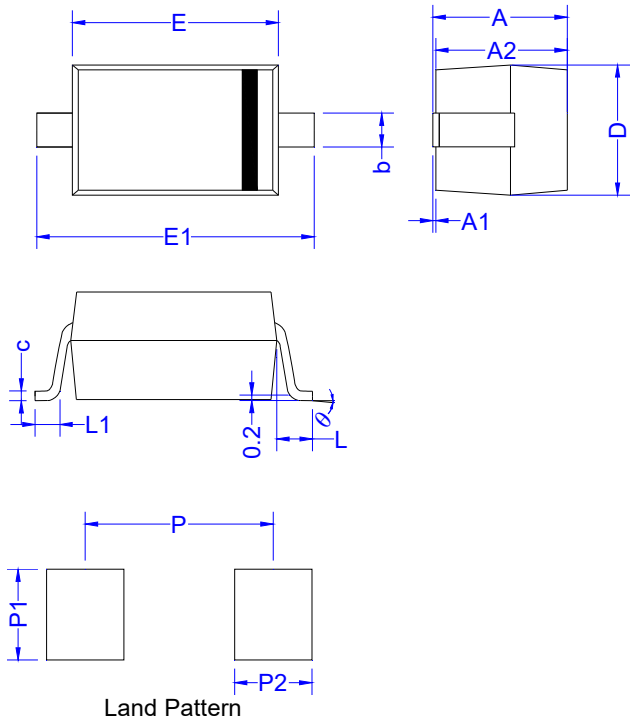

Symbol	Millimeters		Inches	
	Min	Max	Min	Max
A	1.05	1.25	0.041	0.049
A1	0.00	0.10	0.000	0.004
A2	1.05	1.15	0.041	0.045
b	0.45	0.65	0.018	0.026
c	0.08	0.15	0.003	0.006
D	1.50	1.70	0.059	0.067
E	2.60	2.80	0.102	0.110
E1	3.55	3.85	0.140	0.152
L	0.50REF.		0.020 REF.	
L1	0.25	0.45	0.010	0.018
θ	0°	8°	0°	8°
P	3.24		0.128	
P1	1.00		0.039	
P2	0.80		0.031	

**TAPE AND REEL SPECIFICATION-SOD-123**

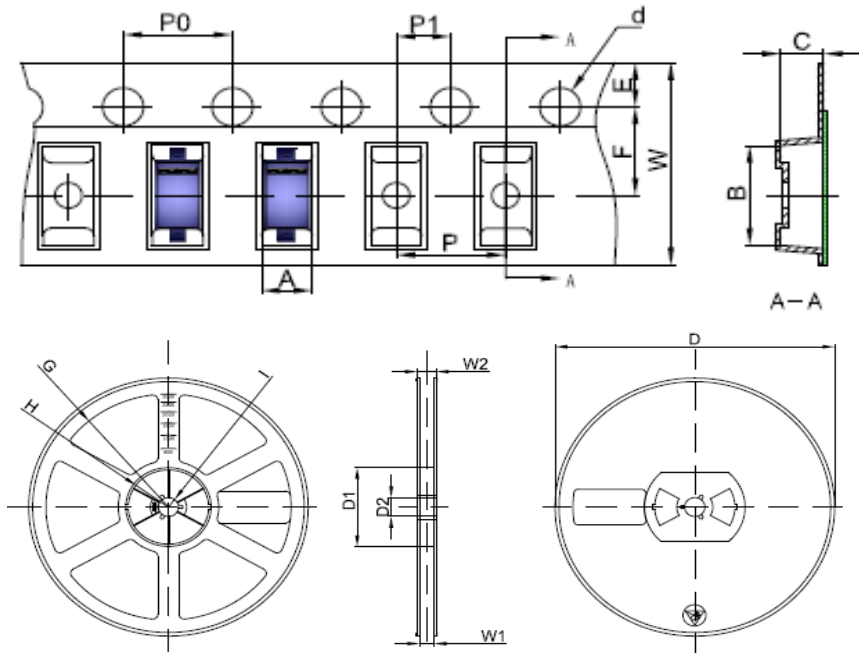

Symbol	Millimeters	Inches
	Typ.	Typ.
A	1.85	0.073
B	3.95	0.156
C	1.57	0.062
d	Φ1.55	Φ 0.061
E	1.75	0.069
F	3.50	0.138
P0	4.0	0.157
P	4.0	0.157
P1	2.0	0.079
W	8.00	0.315
D	Φ178.0	Φ7.008
D1	54.40	2.142
D2	13.0	0.512
G	R78.0	R3.071
H	R25.60	R1.008
I	R6.50	R0.256
W1	9.50	0.374
W2	12.30	0.484

**Packaging description:**

SOD-123 parts are shipped in tape. The carrier tape is made from a dissipative(carbon filled) polycarbonate resin. The cover tape is a multilayer film(heat activated adhesive in nature)primarily composed of polyester film, adhesive layer, sealant, and anti-static sprayed agent. These reeled parts in standard option are shipped with 3,000 units per 7" or 17.8cm diameter reel. The reels are clear in color and made of polystyrene plastic(anti-static coated).

**ORDERING INFORMATION**

OUTLINE	PACKAGE	REEL SIZE	QUANTITY PER REEL
TAPING	SOD-123	7 Inch	3,000PCS

**RATINGS AND CHARACTERISTICS CURVES** ( $T_A=25^{\circ}\text{C}$ , unless otherwise noted)

Fig.1 Power dissipation vs lead temperature

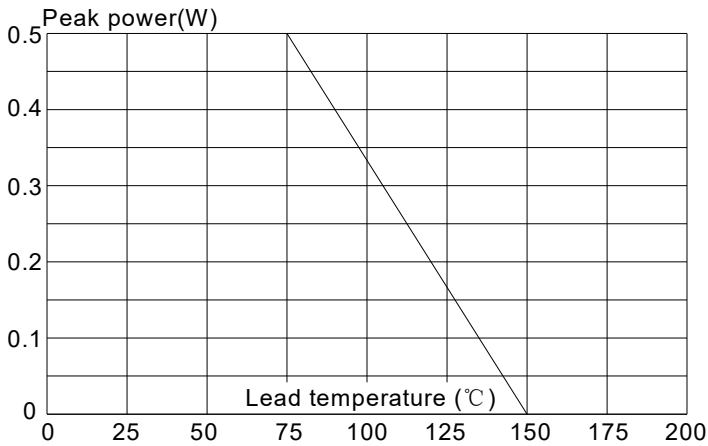
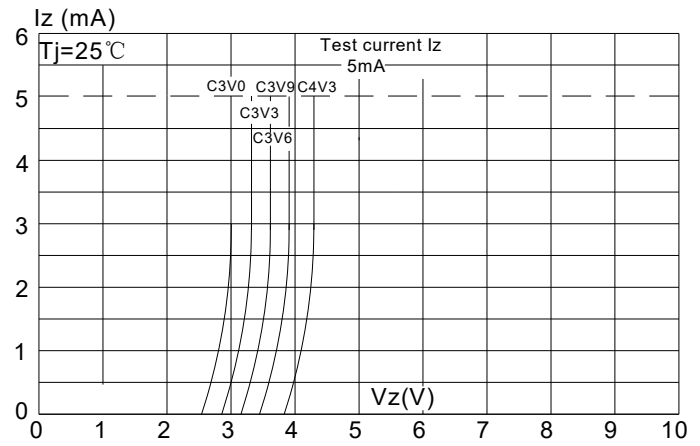

Fig.2 Zener breakdown characteristics



JieJie products are not designed for, and shall not be used for, any purpose (including, without limitation, automotive, military, aerospace, medical, life-saving, life-sustaining or nuclear facility applications, devices intended for surgical implant into the body, or any other application in which the failure or lack of desired operation of the product may result in personal injury, death, or property damage) other than those expressly set forth in applicable JieJie product documentation. Warranties granted by JieJie shall be deemed void for products used for any purpose not expressly set forth in applicable JieJie documentation. JieJie shall not be liable for any claims or damages arising out of products used in applications not expressly intended by JieJie as set forth in applicable JieJie documentation. The sale and use of JieJie products is subject to JieJie terms and conditions of sale, unless otherwise agreed by JieJie.

Information furnished in this document is believed to be accurate and reliable. However, Jiangsu JieJie Microelectronics Co., Ltd. assumes no responsibility for the consequences of use without consideration for such information nor use beyond it.

Information mentioned in this document is subject to change without notice, apart from that when an agreement is signed, Jiangsu JieJie complies with the agreement.

Products and information provided in this document have no infringement of patents. Jiangsu JieJie assumes no responsibility for any infringement of other rights of third parties which may result from the use of such products and information.

This document is the 1.1st version which is made in 26-May-2026. This document supersedes and replaces all information previously supplied.

 is a registered trademark of Jiangsu JieJie Microelectronics Co., Ltd.

Copyright ©2026 Jiangsu JieJie Microelectronics Co., Ltd. Printed All rights reserved.